

SHIRE 70WB

70hp @
2500rpm

BARRUS
WORKBOAT RANGE



Fuel filter with
water drain separator



Jacketed dry exhaust manifold



PRM 260 hydraulic gearbox

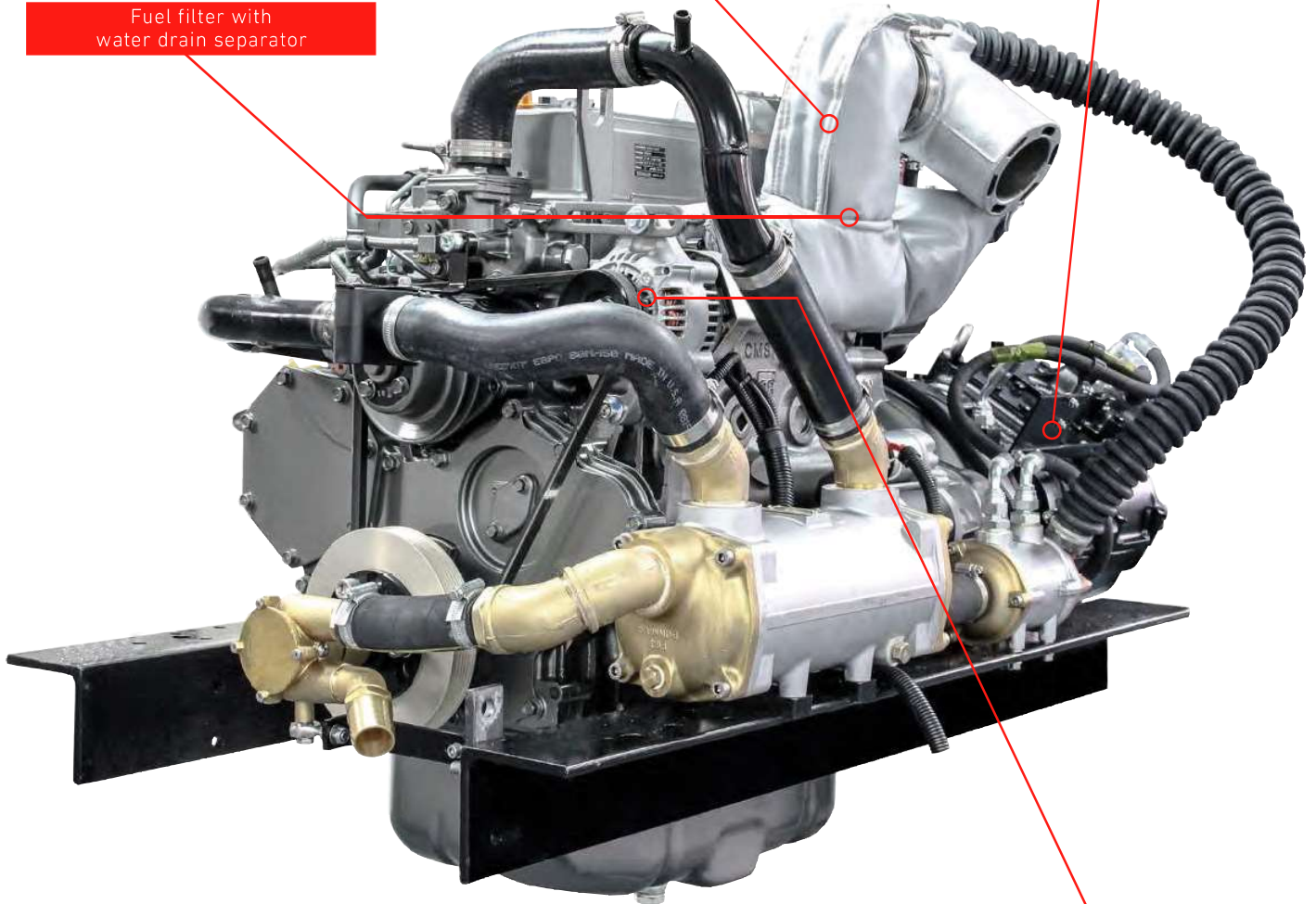

50 Amp 12V alternator

Type	Yanmar Diesel
Number of Cylinders	4
Displacement	3319 cc
Max HP (ISO 3046/1)	70 hp @ 2500
Electrical System	50 amp 12V alternator
Cooling System	Fresh water cooled with heat exchanger
Gearbox	PRM 280 Hydraulic
Dry Weight (inc gearbox)	400 kg

Additional Standard Specification

250 hour engine oil and filter change
Fully dyno tested
Fuel pre filter with water drain
Full size replaceable air filter for maximum filtration and noise reduction
Engine driven raw water pump
Easy access to service items from top of engine (filters, anodes, fuses, water pump)
Morse 33C compatible engine speed and shift control connections
Flexible fuel lines, comply with ISO 7840
Engine and gearbox sump oil drain pump
Engine extension loom - 2.3 metres
Deluxe control panel, which includes specification of basic panel with additional oil pressure, water temp, gauges and voltmeter
Dry exhaust manifold with stainless steel water injected elbow
Anti vibration mounts and adjusting screws
Bulkhead mounted coolant bottle, hoses and clips
PK6 crankshaft pulley providing a drive for additional pump, alternator etc.
Owners handbook
2 and 3D full CAD installation drawings available
Delivered on standard euro pallet
2 Year Warranty on engine and components
1 Year Warranty on all electrical components

Accessories & Options

Remote coolant header tank	Standard
Engine oil	Standard
Engine coolant / anti-freeze	Standard
Stainless steel water injection exhaust elbow	Standard
PTO for rail mounted items	Optional
Crank mounted stub shaft to customers spec	Optional
SAE 9T gear driven PTO, at 0.9 engine speed	Optional
Seawater strainer	Optional
Flexible fuel line (2 x 1m)	Standard
Diesel fuel filter / water separator	Standard
Electric fuel lift pump	Standard
Remote shift control and cables	Optional
Gearbox ratio options	Optional
Flexible output coupling	Optional
Various prop and stern gear components	Optional
Calorifier connections	Optional
Gearbox upgrade	Optional
70 amp alternator	Optional
Domestic travel power up to 5kW 230V	Optional

Dimensions

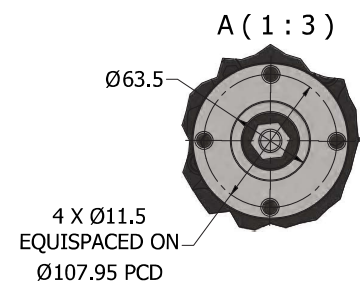
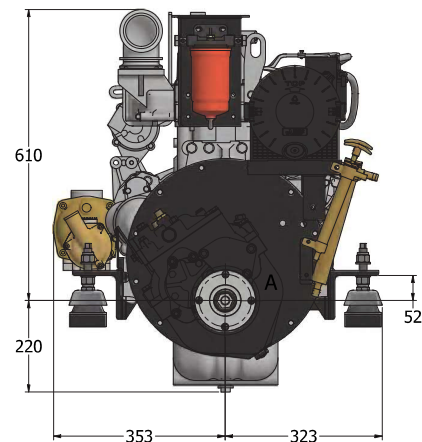
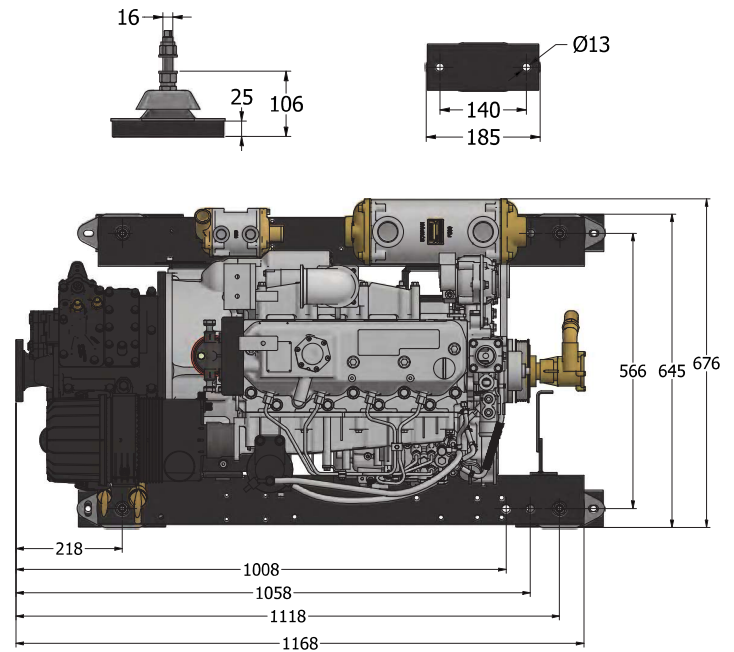

Specifications and/or prices are subject to change without notice.
Every effort is made to produce sales literature and price lists that are accurate and current.

Shire - Engineered and manufactured in the UK by Barrus

E. P. Barrus Ltd., Glen Way, Launton Road, Bicester, Oxfordshire, OX26 4UR
Tel: 01869 363636 www.barrus.co.uk

SHIRE