

SHIRE 30WB

29hp @
3200rpm

BARRUS
WORKBOAT RANGE



Water cooled manifold



Fuel filter with
water drain separator



PRM 150 hydraulic gearbox

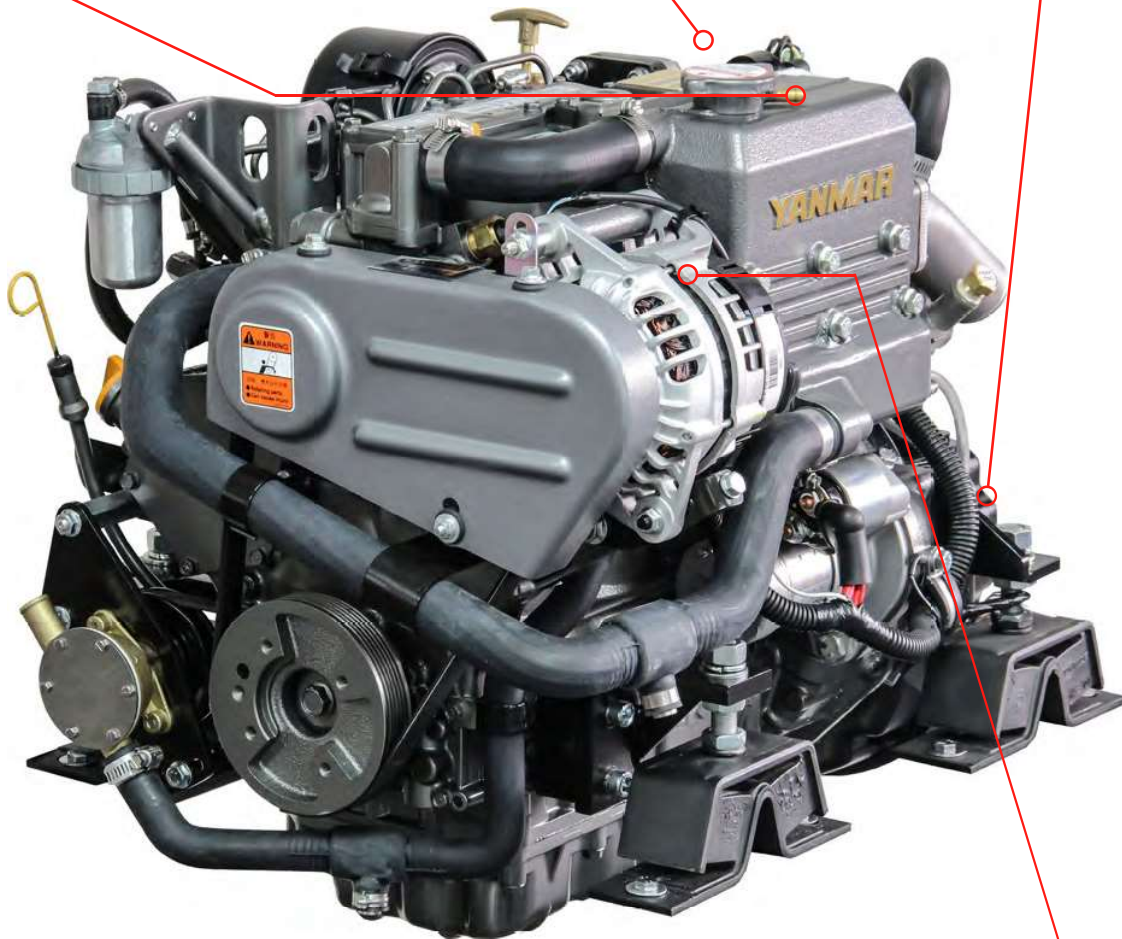

125 Amp 12V alternator

Type	Yanmar Marine Diesel
Number of Cylinders	3
Displacement	1266 cc
Max HP (ISO 3046/1)	29 hp @ 3200rpm
Electrical System	125 amp 12V alternator
Cooling System	Fresh water cooled with heat exchanger
Gearbox	PRM 150 Hydraulic
Dry Weight (inc gearbox)	153 kg

Additional Standard Specification

250 hour engine oil and filter change
Fully dyno tested
Long life heavy duty raw water pump
Fuel filter with water drain
Easy access to service items from top of engine (filters, fuses, water pump)
Morse 33C compatible engine speed and shift control connections
Engine extension loom - 3 metres
Heat exchanger water cooled exhaust manifold with stainless steel water injected elbow 50mm (2") outlet
Anti vibration mounts and adjusting screws
Standard control panel with tacho and warning lights
Owners handbook
2 and 3D full CAD installation drawings available
Delivered in box
2 Year Warranty on engine and components
1 Year Warranty on all electrical components

Accessories & Options

Remote coolant header tank	Standard
7° down angle gearbox	Optional
Engine oil	Standard
Engine coolant / anti-freeze	Standard
Stainless steel water injection exhaust elbow	Standard
Basic control panel (warning lights only)	Optional
Deluxe control panel (tacho, oil, pressure, coolant temp, voltage gauges)	Optional
Engine oil sump pump	Standard
High flow crankshaft mounted seawater pump	Optional
Crank mounted stub shaft for PTO (size optional)	Optional
Primary and secondary fuel filter set-up	Standard
Electric stop solenoid	Standard
Remote shift control and cables	Optional
Gearbox ratio options	Optional
Flexible output coupling	Optional
Calorifier connections	Optional
Additional belt	Optional

Standard Control Panel



Dimensions

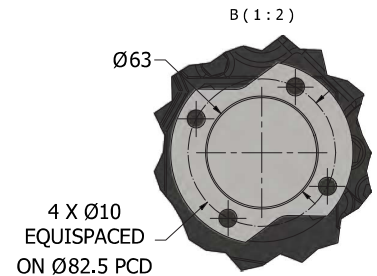
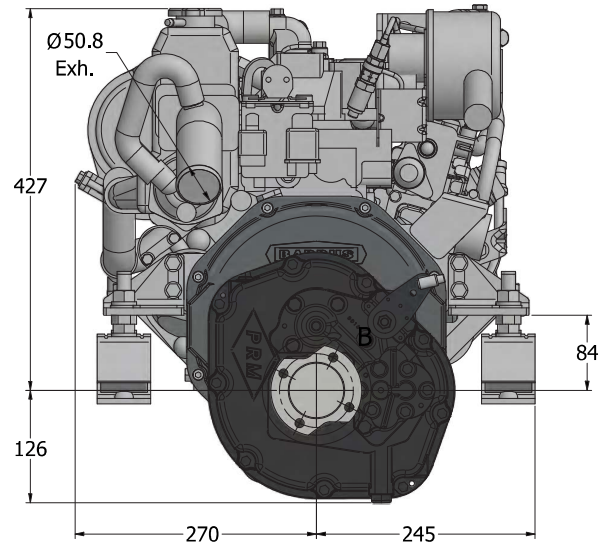
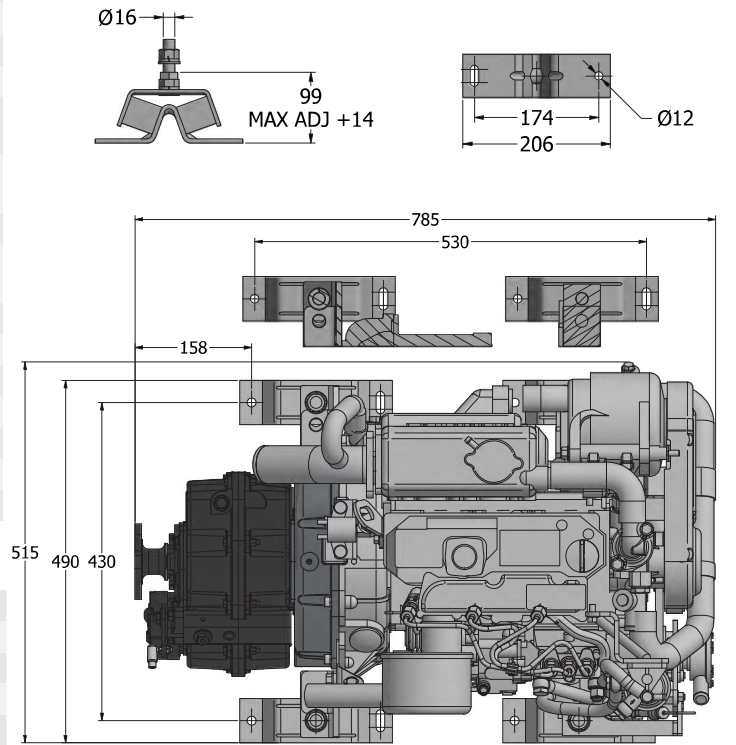

The Power Behind The Brands

Specifications and/or prices are subject to change without notice. Every effort is made to produce sales literature and price lists that are accurate and current.

Shire - Engineered and manufactured in the UK by Barrus
 E. P. Barrus Ltd., Glen Way, Launton Road, Bicester, Oxfordshire, OX26 4UR
 Tel: 01869 363636 www.barrus.co.uk

SHIRE