

SHIRE 130WB

130hp @
2500rpm

BARRUS
WORKBOAT RANGE



120 Amp 12V alternator



Fuel filter with
water drain separator



Jacketed dry manifold with water
injection elbow

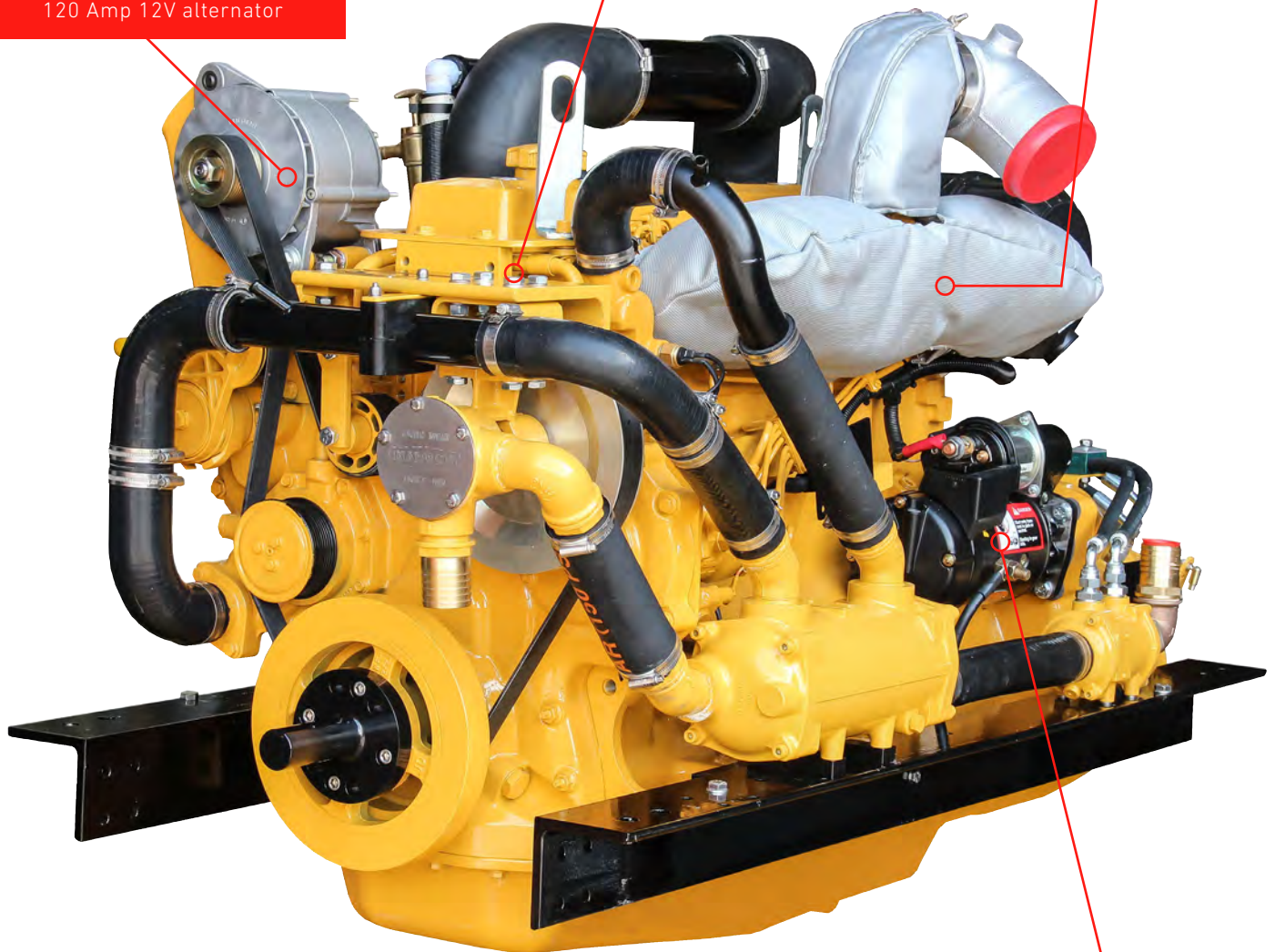

Type	John Deere Diesel
Number of Cylinders	6
Displacement	6800 cc
Max HP (ISO 3046/1)	130 hp @ 2500
Electrical System	120 amp 12V alternator
Cooling System	Fresh water cooled with heat exchanger
Gearbox	PRM 500 Hydraulic
Dry Weight (inc gearbox)	845 kg



PRM 500 hydraulic gearbox

Additional Standard Specification

370 hour engine oil and filter change
Fully dyno tested
Full size replaceable air filter for maximum filtration and noise reduction
Easy access raw water pump
Easy access to service items from top of engine (filters, anodes, fuses, water pump)
Morse 33C compatible engine speed and shift control connections
Engine and gearbox sump oil drain pump
Engine extension loom - 2.3 metres
Deluxe control panel, which includes specification of basic panel with additional oil pressure, water temp, gauges and voltmeter
Anti vibration mounts and adjusting screws
Owners handbook
2 and 3D full CAD installation drawings available
2 Year Warranty on engine and components
1 Year Warranty on all electrical components

Accessories & Options

Remote coolant header tank	Standard
Engine oil	Standard
Engine coolant / anti-freeze	Standard
Stainless steel water injection exhaust elbow	Standard
PTO for rail mounted items	Optional
Crank mounted stub shaft for PTO (size optional)	Optional
Remote shift control and cables	Optional
Gearbox ratio options	Optional
Flexible fuel line (2 x 1 m)	Standard
Diesel fuel filter / water separator	Standard
Flexible output coupling	Optional
Various prop and stern gear components	Optional
Calorifier connections	Optional
24 volt electrics	Optional
Gearbox driven PTO	Optional
PK6 crankshaft pulley providing a drive for additional pump, alternator etc.	Optional
Domestic travel power up to 5kW 230V	Optional
Upgrade gearbox	Optional

Dimensions

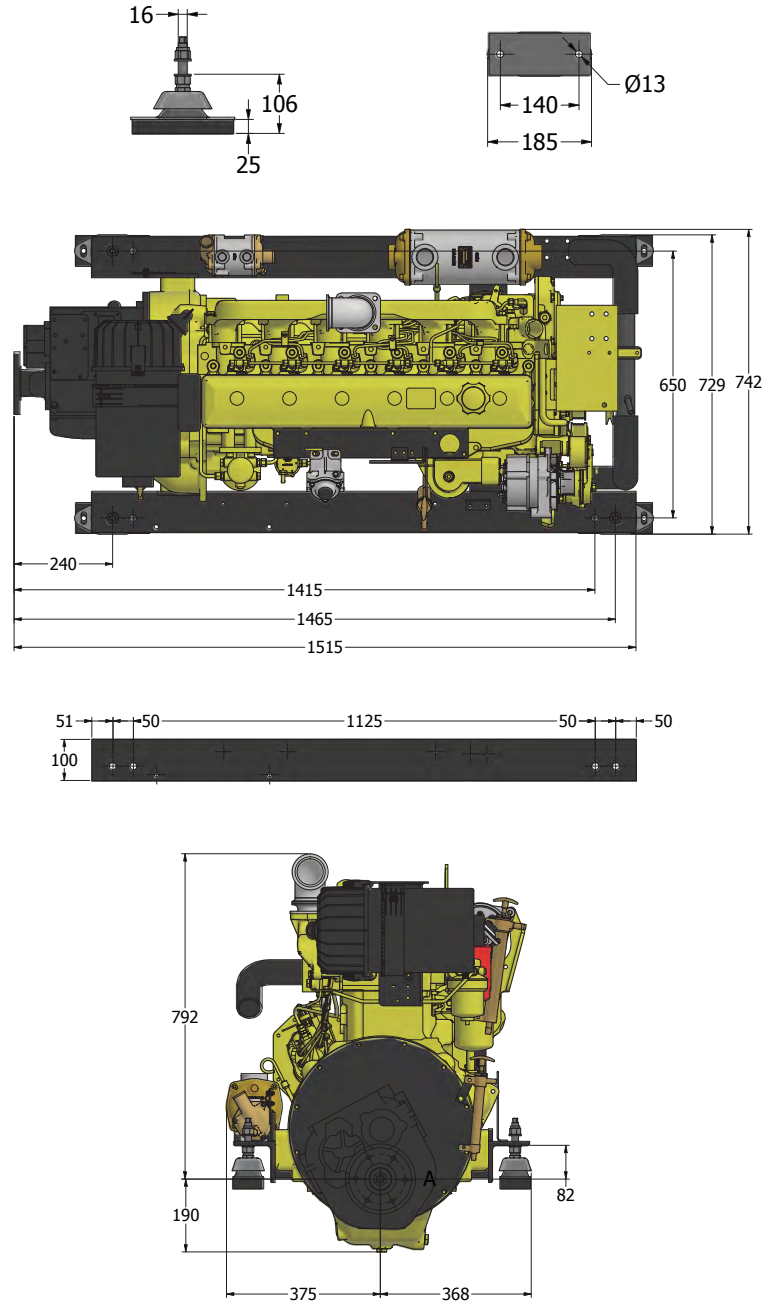

Deluxe Control Panel

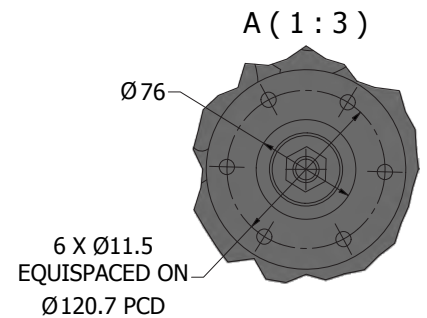

Specifications and/or prices are subject to change without notice. Every effort is made to produce sales literature and price lists that are accurate and current.

Shire - Engineered and manufactured in the UK by Barrus

E. P. Barrus Ltd., Glen Way, Launton Road, Bicester, Oxfordshire, OX26 4UR
Tel: 01869 363636 www.barrus.co.uk

