

# Python-Drive flexible drive/thrust assembly

# Ratings, pleasure craft

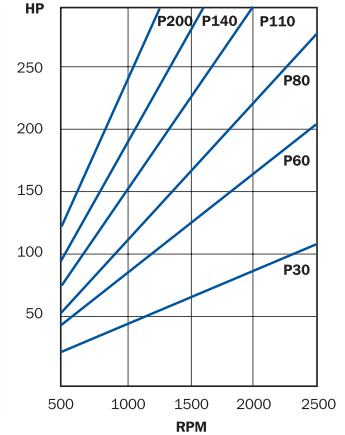
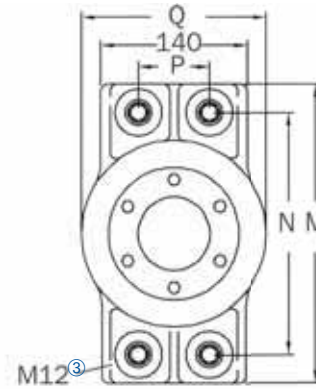
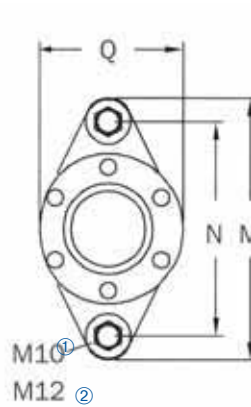
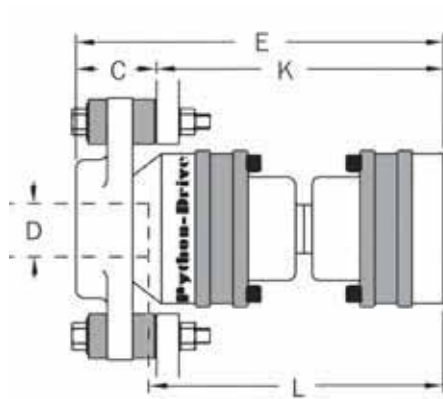

## Dimensions in millimetres (mm) Thrust (T) in Kg

	Bolting	D*	C	E	K	L**	M	N	P	Q	T
P30-R	①	19-30	54	246	192	186	175	143	—	100	430
P60-K	②	30-40	59	296	237	206	189	157	—	116	570
P80-S	②	30-45	57	351	294	236	224	170	—	148	1200
P110-S	②	35-45	57	340	283	215	224	170	—	148	1200
P110-T	③	35-51	65	350	285	227	284	230	68	117	1800
P140-T	③	40-55	65	350	285	227	284	230	68	117	1800
P200-T	③	40-60	65	435	400	321	284	230	68	117	1800

\*\* Longer lengths available at extra charge

Made in Europe

\* Imperial shaft sizes also available

## Series Maximum shaft R.P.M.

Joint angle, each	8°	7°	6°	5°	4°	3°	2.5°	2°	1.5°	0°	
P30-P140	30-40	1000	150	2000	2500	3500	4500	4500	4500	4500	0
P200						1200	1500	1750	2250	3000	0

**Maintenance-free thrust assembly**

**Gearbox flange for choice of commonly available gearbox included**

**Detailed selection advice available free-of-charge**

**1:10 taper coupling available in lieu of clamp coupling**

**No thrust is transmitted to engine**