

Mechanical engagement gearboxes

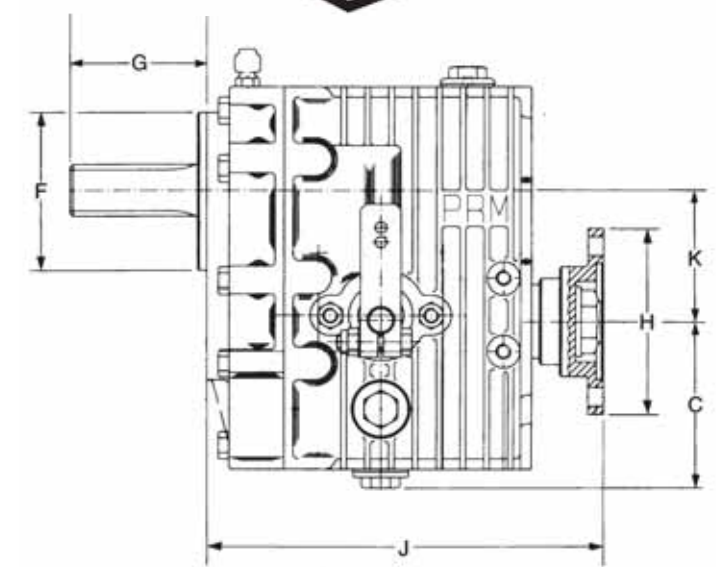
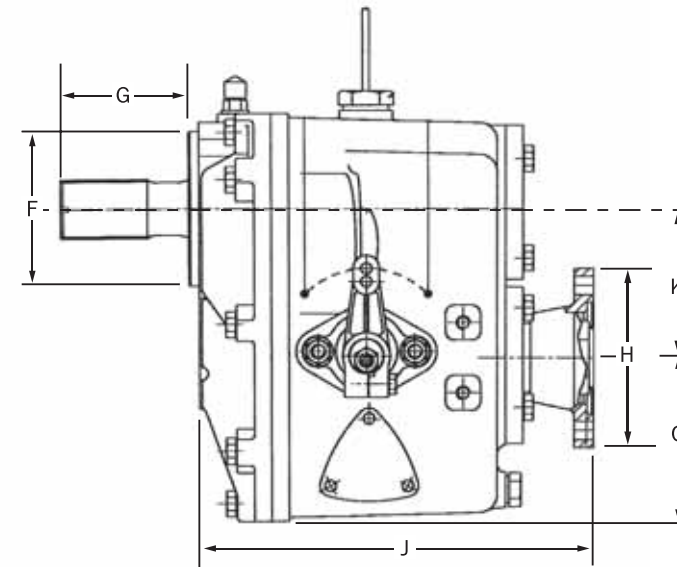
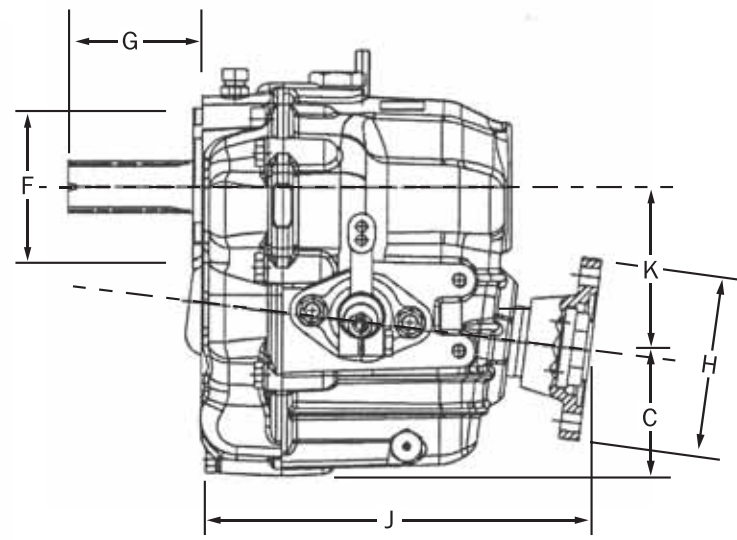
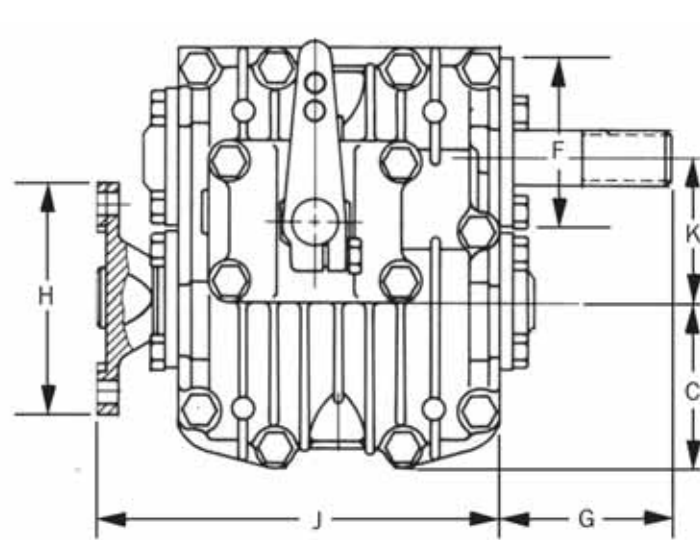

Make	ZF (PREVIOUS HURTH HBW TYPES)							TECHNODRIVE				PRM			
Model	10M (100)	12M (125)	15M (150)	15MIV (150V)	15MA (150A)	25M (250)	30M	TMC40 M&P TYPES	TMC60 M&P TYPES	TMC60A	TMC260	80	90	120	125
REDUCTION	-		1.56 ^o			-		1.45 ^o	1.54 ^o	-	1.54 ^o	2.00 ^o	2.00 ^o	2.04 ^o	2.00 ^o
RATIOS :1	(1.86 ^A)	(1.95 ^A)	1.88 ^o	2.13 ^o	1.88 ^o 2.14 ^o	1.88 ^o	2.15 ^o	2.00 ^o	2.00 ^[O]	2.00 ^o	2.00 ^[A]	[2.47 ^o]	[2.47 ^o]	[2.47 ^o]	[2.47 ^o]
^A As engine rotation	2.05 ^o	2.14 ^o	(1.95 ^A)	(2.22 ^A) 2.72 ^o	(1.95 ^A)	(2.10 ^A) 2.27 ^o	(2.64 ^A)	(2.13 ^A)	[2.45 ^{O(A)}]	(2.17 ^A)	2.47 ^[A]	[2.50 ^A]	[2.50 ^A]	(2.50 ^A)	(2.50 ^A)
^o Opposite rotation	(2.72 ^o)	(2.63 ^o)		(2.99 ^o)	2.63 ^o	(2.74 ^o)	2.70 ^o	2.60 ^o	(2.83 ^o)	2.45 ^o	(2.88 ^o)			(3.06 ^o)	(3.06 ^o)
Weight W Kgs	10	13	13	20	13	18	33	9	14	16	19	12	12	16	16
Length J mm	180	192	192	265	194	218	254	160	225	218	255	196	196	216	216
Drop K mm	62	72	72	147 at 15°	94 at 8°	85	90	67.5	77	91@7°	85	72	72	72	72
Depth C mm	73	86	86	106	76	93	94	83	84	71	93	90	90	90	90
Spigot F mm	88	88	88	88	88	92	92	88	88	88	88	88	88	88	88
Shaft G mm	75	75	75	75	75	83	62	75	75	75	80	75	75	75	75
Flange H ins	4	4	4	4	4	4	4	4	4	4	4	4	4	4	4
Max Diesel HP/100*	1.4(0.9)	1.8(1.5)	2.0	2.0(1.5)	2.0(1.5)	3.6(2.4)	3.2(2.6)	1.0(0.7)	2.1[1.7](1.4)	1.8(1.2)	3.0(2.5)[2.0]	1.1[0.9]	1.25[1.0]	1.7[1.3](1.1)	1.7[1.3](1.1)
Max RPM	5000	5000	5000	5000	5000	5000	5000	4500	5000	4500	5000	5000	5000	5000	5000
Cooler size	H	H	H	H	H	H	H	—	—	—	—	—	—	—	—
Lubricant	Automatic transmission fluid, Dextron ZF 10M, 12M, 15M and 25M gearboxes may be ordered for non-standard input rotation May be locked in astern or trailed while sailing Made in European Community							Automatic transmission fluid, Dextron May be locked in astern or trailed while sailing Made in European Community				Engine Oil May be locked in astern or trailed while sailing Made in European Community, except 90 & 125			

*Pleasure boat rating for 4 cylinder engines. 2 or 3 cylinder ratings are lower
 Lancing Marine are able to modify any of these boxes for horizontal offset at extra charge
 Installation parts available include:- Flywheel housings and adaptors, flywheel drive plates, oil coolers, shift cable connection kits, flexible couplings, shaft half couplings, C.V shafts and thrust bearings

Lancing Marine are able to modify any of these boxes for horizontal offset at extra charge
 Installation parts available include:- Flywheel housings and adaptors, flywheel drive plates, oil coolers, shift cable connection kits, flexible couplings, shaft half couplings, C.V shafts and thrust bearings

All gearboxes may be operated with single lever remote controls, and will accept propeller shaft thrust. Always fit a flexible coupling