

LM Transom Drives

The New All-British designed and manufactured **LM TRANSOM DRIVE** that increases the operational efficiency of sportsboats and fast motor cruisers.

These rugged units are capable of being coupled to the more powerful petrol engines of which the Ford V6, Jaguar 4.2, and the American 'Small and Big Block' V8's are typical, PLUS diesel engines of up to 600 h.p. through a ZF, PRM or other suitable gearbox.

There are three models to cover the range of engine applications. Each model comes complete with hydraulic steering as standard.

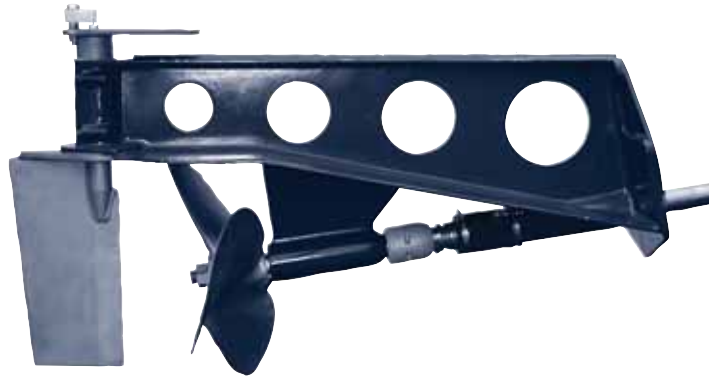

The advantages of the **LM TRANSOM DRIVE** over other forms of marine propulsion drives apply right through the designer - boatbuilder - user spectrum because:-

LM TRANSOM DRIVE allows for inboard engine installation in a position close to the transom.

LM TRANSOM DRIVE propeller shaft runs at an angle of only 8°.

LM TRANSOM DRIVE has direct-drive from gearbox eliminating the power loss experienced in sterndrives.

LM TRANSOM DRIVE requires a smaller aperture cut into the boat's transom than for a sterndrive.

LM TRANSOM DRIVE has no gears to wear or break.

LM TRANSOM DRIVE has a smaller underwater profile, causing less underwater drag.

LM TRANSOM DRIVE has a high rake surface piercing propeller, which when running partially out of the water, helps trim the bow of the boat up on high speed running AND YET when fully immersed still gives transom lift to ensure easy planing.

LM TRANSOM DRIVE subjects steering systems to very light steering loads due to its balanced rudder design.

LM TRANSOM DRIVE 14 rudder forms a propeller guard.

LM TRANSOM DRIVE 14 has a splined propeller shaft enabling the propeller to be quickly removed, especially applicable to trailable craft where propeller damage can occur during transit.

Dimensions

	A	B	C	D	F	H	J	K	L	M	N	O	WEIGHT excl. prop
14"	890	510	380	305	—	1¼"	190	215	255	—	85	610	37
17" STD	1215	675	410	355	—	1¾"	190	280	320	—	114	835	67
20" STD	1300	725	520	355	—	2"	190	280	370	—	114	835	90
17" SEP	1000	708	465	355	315	1¾"	—	290	418	570	114	835	113 (pair)
20" SEP	1025	708	465	355	315	2"	—	290	418	570	114	835	155 (pair)

All measurements are in mm, unless otherwise stated, and are approximate.

Weights in Kg. and for separate rudder units include two drives and one rudder assembly.

14" units

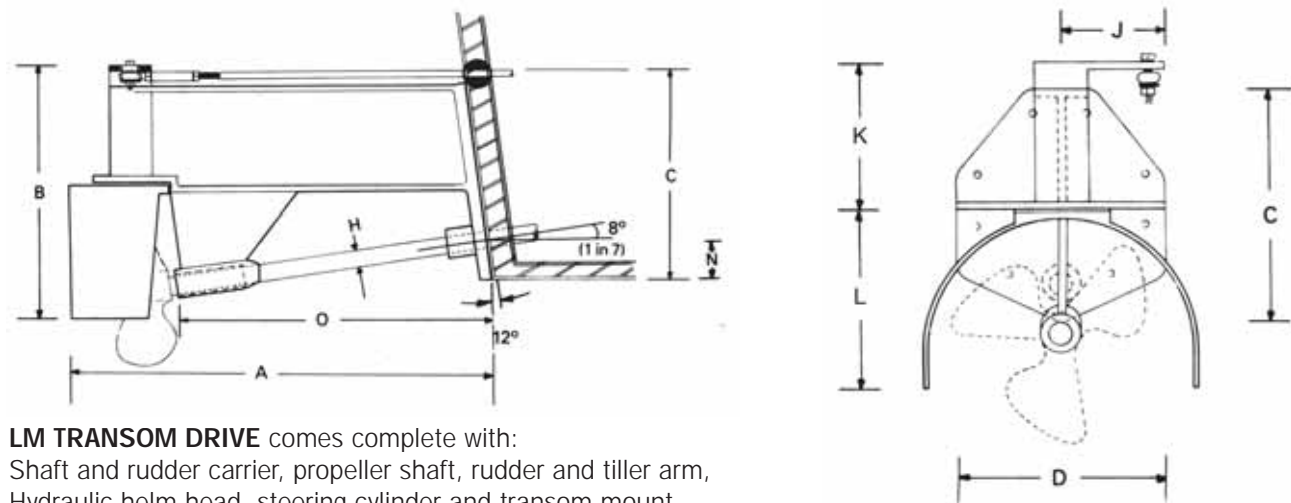

LM TRANSOM DRIVE comes complete with:
Shaft and rudder carrier, propeller shaft, rudder and tiller arm, Hydraulic helm head, steering cylinder and transom mount, hoses and connections, Shaft, bearing and seal assembly.

Extras:

Propeller, Shaft coupling and flexible coupling to suit engine/gearbox being installed, Set of transom bolts.

Installation drawings

Our policy is one of continual improvement and specifications may change without notice

17" & 20" units with standard rudder

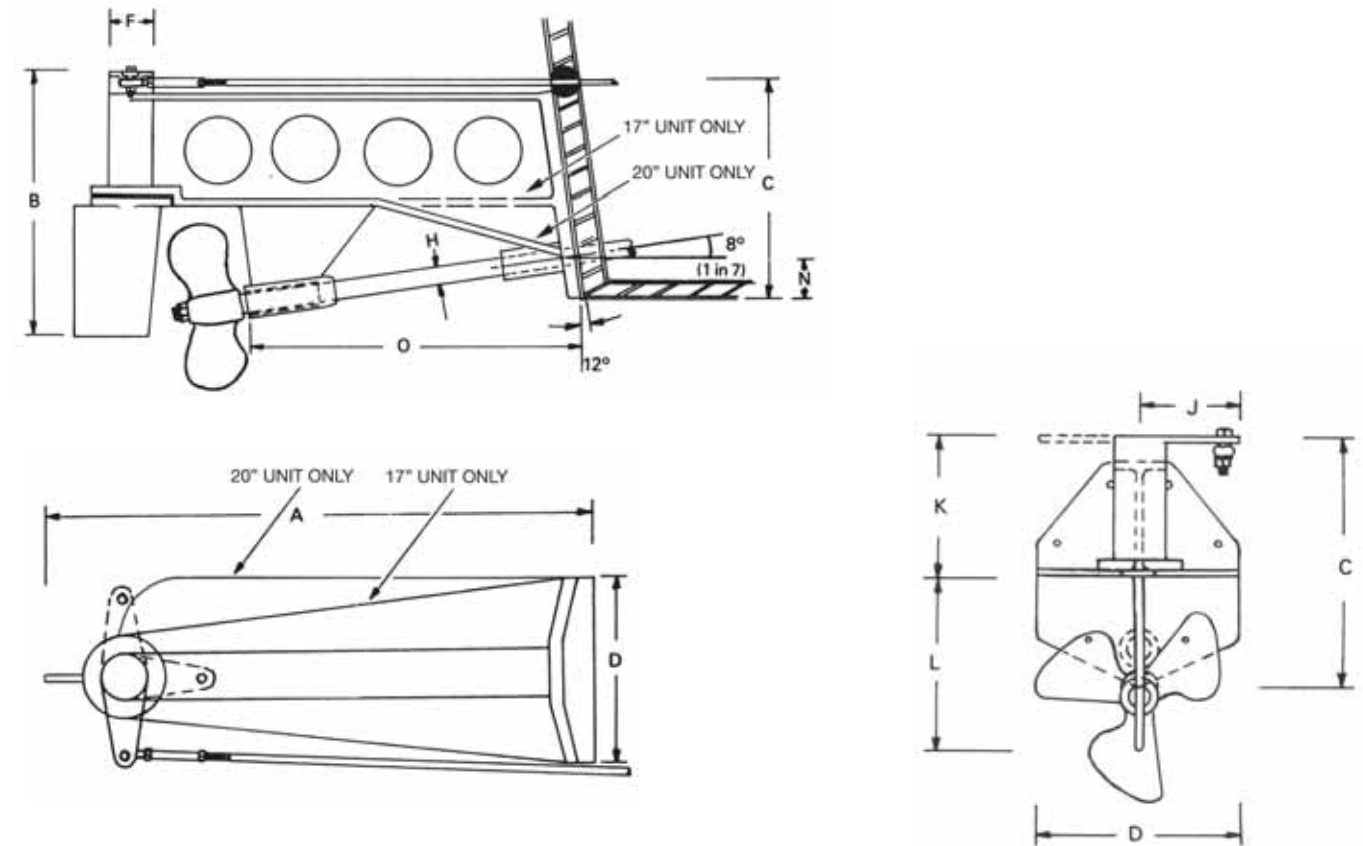

17" & 20" units with separate rudder

