

# Sternpower 100 Series Heavy Duty Sterndrives

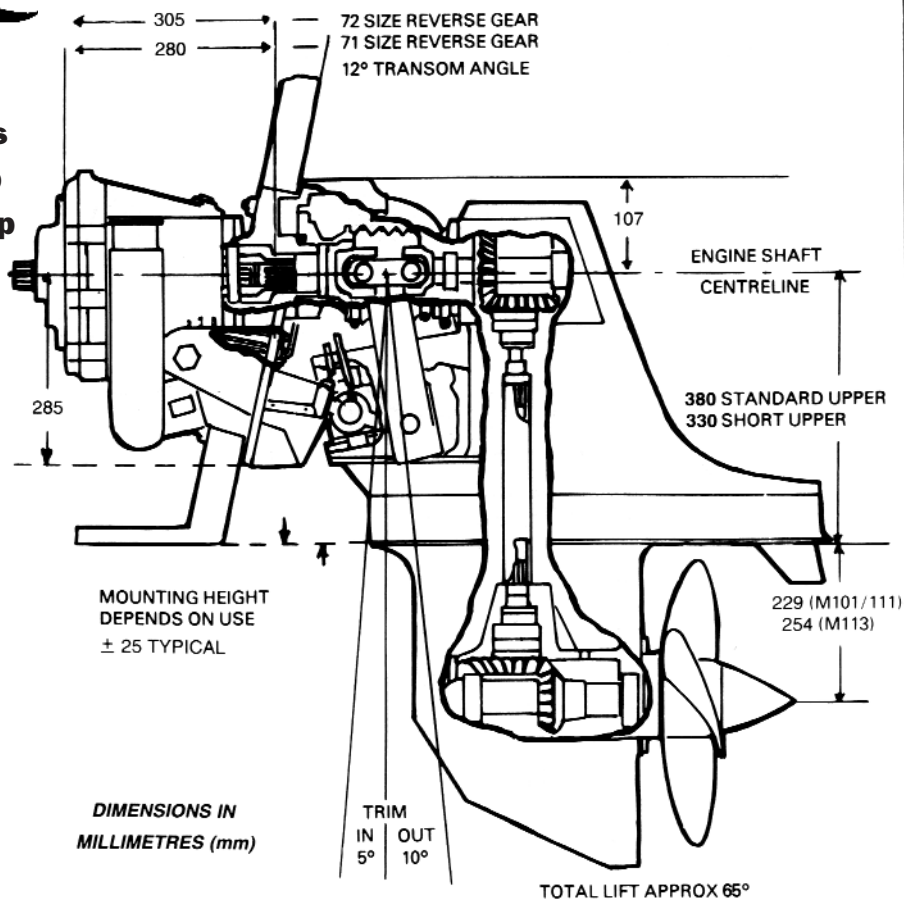

**100 Series Heavy Duty Sterndrives  
for Petrol engines 80 hp to 450 hp  
and Diesel engines 80 hp to 280 hp**



## General Characteristics

- Built-in Hydraulic Steering
- Built-in Electric/Hydraulic Trim and Tilt
- Kick-up Protection from Hydraulic Valves in Piston Heads
- 65° Total Tilt Angle
- Left-hand or Right-hand Propeller Rotation to choice
- Anodes provided for Cathodic Protection
- Helm Head and Hoses (or tie-bar assembly) included
- Trim Control Switch and Loom included

## Optional extras

- Integral or Remote Mounted Hydraulic Gearbox
- Remote Shaft Kit
- Drive Leg Extension
- Propeller
- Through-Transom Exhaust Outlet
- Through-Transom Water Pickup Kit
- Propeller Thrust Gauge
- Power Trim Position indicator
- 24v or Insulated Return Electrics

## Technical data

Model	101	111	113	Max HP/100RPM
Maximum prop diameter	17"	17"	19"	
Prop type	Cushion hub		Solid hub	
Reduction ratios		1.00	1.00	10.0
		1.16	1.16	10.0
	1.32*	1.32	1.32	7.5
		1.54	1.54	7.5
		1.66	1.66	6.8
*Limited to 6.7HP/100RPM		2.00	2.00	5.7
Boat speed range	0 – 60 MPH		0 – 40 MPH	
Max all-up weight per drive (tons)	3	3	4	
Weight (Kgs) including lubricant (excluding hydraulic gear)	111	111	114	

**Choose Model 101 & 111 for lightweight boats and higher speeds**

**Choose Model 113 for heavier boats and economical cruising**