

# New Holland Diesel 6 cylinder

**NHD675L - 128 HP at 2000 RPM**  
**NHD675 - 160 HP at 2500 RPM**

**New Holland parts support throughout Europe, the Americas and countries worldwide**

Engine specifications may vary as improvements are introduced Specifications are subject to change without notice and are not for engineering purposes

See the Lancing Marine Price Book for Complete Installation Kit Lancing Marine reserve the right to alter specifications without notice

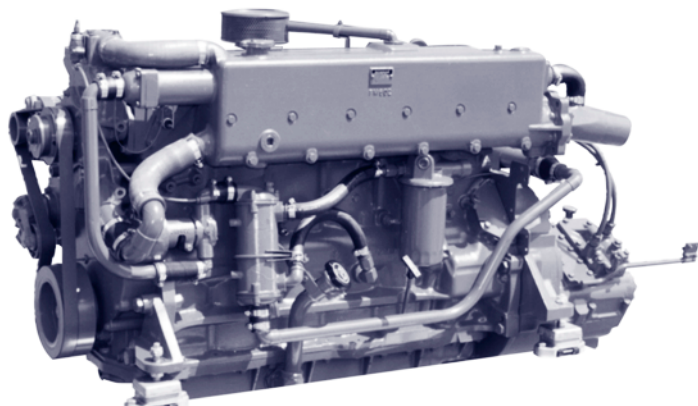

## Design Features

### Engine

Low noise, high strength, rugged bottom end with 7 main bearings, piston cooling, thick wall parent bore. Large diameter valves to improve volumetric efficiency. High compression ratio for faster starts and warm ups with reduced white smoke.

### Fuel system

High nozzle opening pressures for high fuel efficiency and low smoke. Self air purge fuel pump, automatic excess fuel and timing retard for excellent cold starting, and thermostart for -20° operation.

### Reliability

A robust designed engine for long life. Cast iron crankcase for maximum rigidity.

### Serviceability

Piston jet oil cooling for extended life. Long filter and oil change intervals (300 hours). Self adjusting poly vee drive belt for alternator and fresh water pump for low slippage with minimal power loss and longer bearing life.

## Variation to standard specification (see inside front cover) and extra optional items for this engine type

### Additional standard items

Electric run/stop control  
 Full power dynamometer test on 160HP engine  
 Fuel-in-water sensor

### Optional items

Aluminium sump  
 Continuous run bilge pump  
 Power take-off pulley or shaft  
 Keel cooling and dry exhaust in lieu of heat exchanger system  
 24v electrics

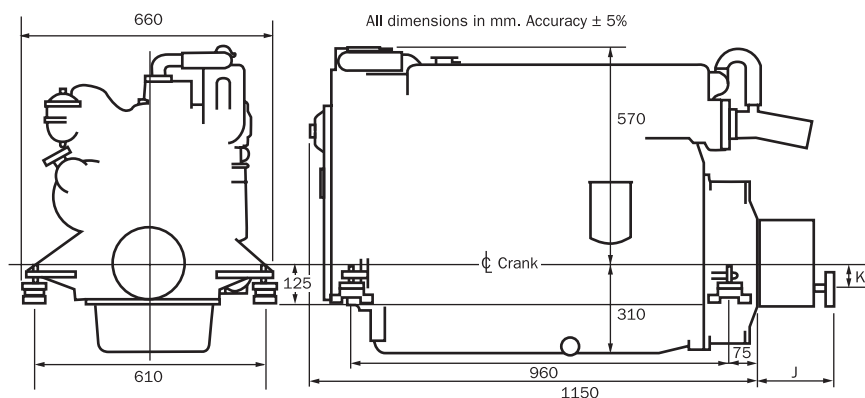

Dimensions J & K can be found in the gearbox specification pages 12 - 16

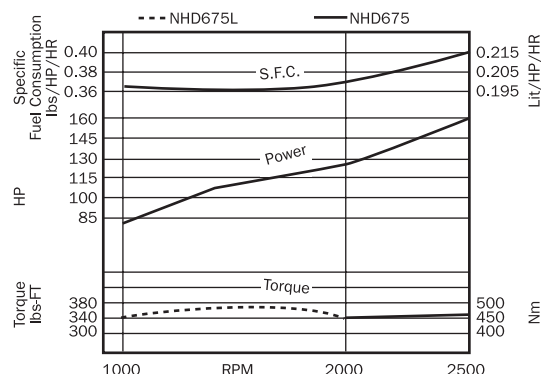

## Detailed specification

Engine model	NHD675L	NHD675	Engine model	NHD675L	NHD675
Power Maximum H.P.	128	160	Max Fuel Consumption, lit/hour	24	32
RPM Maximum	2000	2500	Fuel feed diameter, ins		3/8
Torque Maximum Nm		495	Fuel return diameter, ins		3/8
Cubic capacity, litres		7.5	Exhaust diameter, ins (mm)		3 (75)
Bore, mm		112	Water intake diameter, ins (mm)		7/8 (22)
Stroke, mm		127	Coolant capacity, lit		19
Aspiration		Natural	Oil capacity, lit		21
Engine rotation		Anti-clockwise viewed from rear	Weight, Engine, Kg	627	630
Compression ratio		17.5:1	Guide to sterngear		
Electrics 12v earth return Alt, Amps		70	Max. Prop. dia. for gear ratio 1.5:1 ins	23"	20"
optional 12v insulated Alt, Amps		70 or 105	Min. Shaft Dia. St. St. ins (mm)	1 5/8 (45)	1 5/8 (45)
optional 24v insulated Alt, Amps		40	Speed range for this ratio (knots)	9-18	14-24
Minimum battery size		1X176 AH 12 volt	Max. Prop. dia. for gear ratio 2:1	27"	25"
Minimum starter cable, length=size		0.6M = 70mm <sup>2</sup> /1.2M = 95mm <sup>2</sup>	Min. Shaft Dia. St. St. ins (mm)	1 3/4 (45)	1 3/4 (45)
Engine operating angles			Speed range for this ratio (knots)	6-12	10-20
Engine front down (degrees)		5	Max. Prop. dia. for gear ratio 3:1	39"	33"
Sideways (degrees)		35	Min. Shaft Dia. St. St. ins (mm)	2 1/8 (55)	2 (50)
Engine front up (degrees)		30	Speed range for this ratio (knots)	4-10	5-12