

VELVET		ZF (PREVIOUS HURTH HSW TYPES)						
	5000	25A(250A)	45A(450A)	63A(630A)	80A(800A)	220A	280-1A	301A
	1.0/1.25	1.55	1.26	1.22	1.57	1.23	1.12	1.19
	1.50	1.93	1.51	1.56	1.75	1.53	1.48	1.52
	2.0	(2.29)	2.03	2.04	1.96	1.75	1.75	2.01, 2.30
	2.45	(2.48)	(2.43)	(2.52)	(2.50)	2.04	2.04	2.55
	(2.80)	(2.71)		(2.70)		(2.45)	2.45	2.90
	8°	8°	8°	8°	8°	10°	7°	10°
	49	24	28	44	64	50	73	87
	228	216	228	265	291	246	280	324
	151	115	126	144	160	145	147	56
	97	75	79	82	112	116	113	167
	209	92	209	209	209	111FEM	111FEM	256
	65	83	65	65	76	93	71	88
	5	4	5	5	5 3/4TD	4 3/4TD	5 3/4TD	5 3/4TD
	9.6(8.5)	4.4(3.4)	6.3(5.9)	9.6(8.4)	13.2(12.1)[11.4]	12.5(11.5)	18.8(16.2)	17.2
	5000	5500	5500	5500	4500	4500	3200	3000
	2	1	2	2	3	3HP	4HP	4HP
	ATF	ATF Dextron				SAE30 Engine Oil		

V-Drive version Electric shift controls (not 25A) PTO mountings (not 25A)
 V-Drive versions (not 25A or 45A) Trolling valves (not 25A)

Made in USA Made in Italy

propeller shaft thrust. Always fit a flexible coupling

Mechanical engagement gearboxes

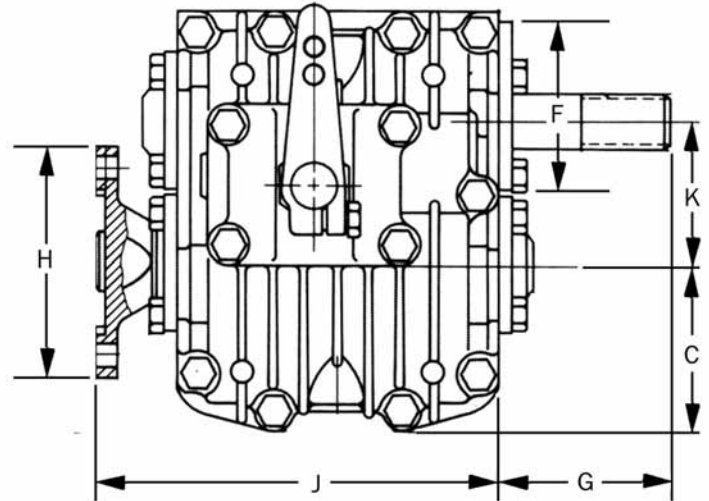
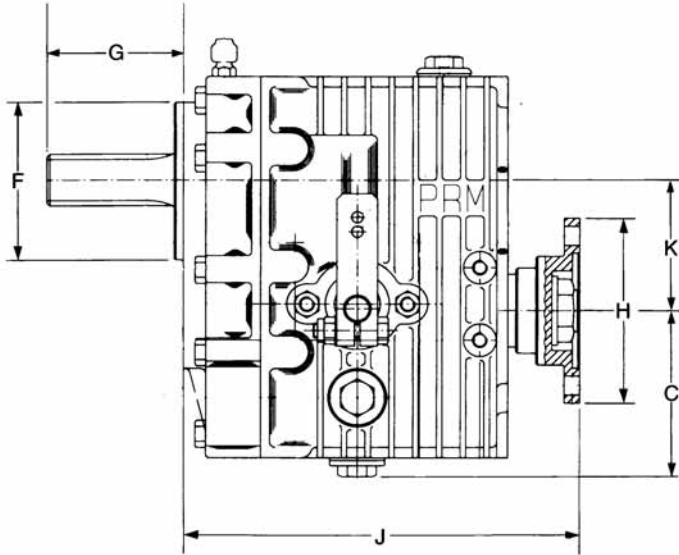

Make	PRM		ZF (PREVIOUS HURTH HBW TYPES)							
Model	80	120	6M	10M (100)	12M (125)	15M (150)	15MIV (150V)	15MA (150A)	25M (250)	30M
REDUCTION RATIOS :1	2.04 ⁰ [2.50 ⁰]	2.04 ⁰ [2.50 ⁰]	-	-	-	1.56 ⁰	-	-	-	-
^A As engine rotation	[2.50 ^A]	(2.50 ^A)	1.86 ^A	1.86 ^A	1.95 ^A	1.88 ⁰	2.13 ⁰	1.88 ⁰ 2.14 ⁰	1.88 ⁰	2.15 ⁰
⁰ Opposite rotation	-	(2.94 ⁰)	2.05 ⁰ (2.72 ⁰)	2.05 ⁰ (2.72 ⁰)	2.14 ⁰ (2.63 ⁰)	1.95 ^A	2.22 ^A 2.72 ⁰ (2.99 ⁰)	1.95 ^A 2.10 ^A 2.27 ⁰ (2.63 ⁰)	2.10 ^A 2.27 ⁰ (2.74 ⁰)	(2.64 ^A) 2.70 ⁰
Weight W Kgs	12	16	10	10	13	13	20	13	18	25
Length J mm	196	232	180	180	192	192	265	194	218	254
Drop K mm	72	72	62	62	72	72	147 at 15°	94	85	90
Depth C mm	81	81	73	73	89	89	106	76	93	94
Spigot F mm	88	88	88	88	88	88	88	88	92	92
Shaft G mm	75	75	75	75	75	74	74	75	83	62
Flange H ins	4	4	4	4	4	4	4	4	4	4
Max Diesel HP/100*	1.3[0.9]	1.7[1.5](1.3)	0.8(0.6)	1.4(0.9)	1.8(1.5)	2.0	2.0(1.5)	2.0(1.5)	3.6(2.4)	3.2(2.6)
Max RPM	5000	5000	5000	5000	5000	5000	5000	5000	5000	5000
Cooler size	-	-	H	H	H	H	H	H	H	H
Lubricant	SAE30 Engine Oil		Automatic transmission fluid, Dextron							

General characteristics

May be locked or trailed while sailing

*Pleasure boat rating

All gearboxes, except PRM120, may be ordered for non-standard input rotation

Made in England

Made in Italy

All gearboxes may be operated with single lever remote controls, and will accept propeller shaft thrust. Always fit a flexible coupling